

# FG-200

## FF Network Integration via Modbus Including Redundancy

- Implementation of FF advantages in Modbus host systems
- Usage as a redundant link
- Interface for Plant Asset Management applications
- Functionally advanced and easy-to-integrate gateway package

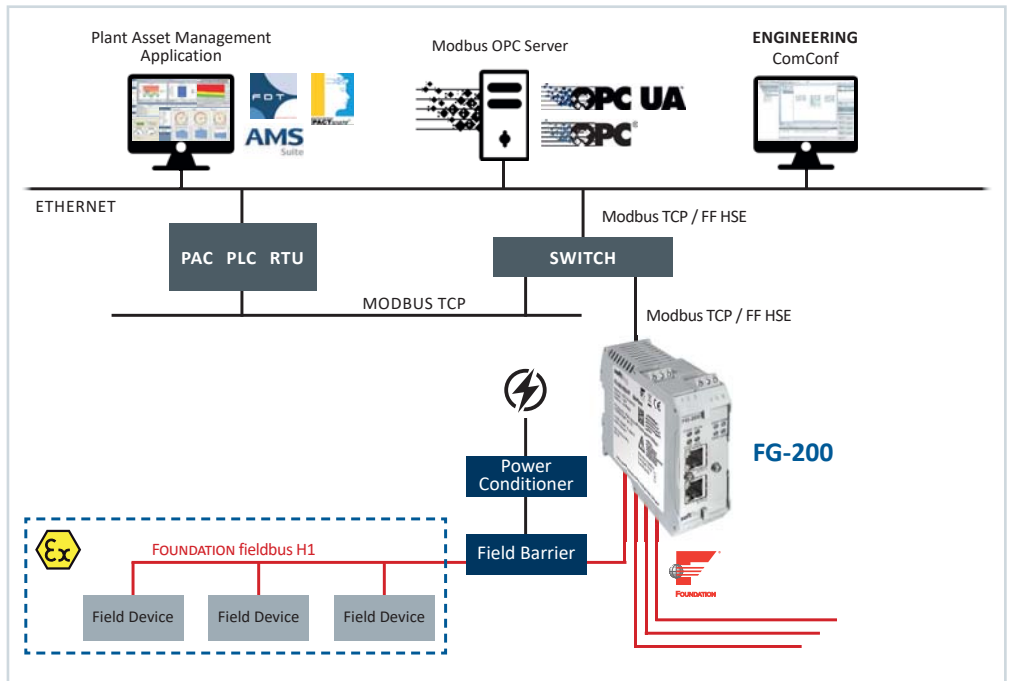

### CAPEX-efficient Integration of FF-devices into Modbus Architectures

- Parallel support of up to 4 FF-H1 channels, each for max. 16 field devices
- Fast access to process data
- Suitable for use in hazardous areas
- Easy Commissioning:
  - Optional support of R. STAHL bus-Carrier Series 9419 and Fieldbus Power Supply 9412 products (cabling reduced to a minimum)
  - Modbus data import to web server reducing mapping efforts

### Device Redundancy

- Redundancy link enabling device redundancy (D-3 according to FF-593)
- Automatic mirroring of configuration data
- Very fast redundancy switch-over

### Prepared for Plant Asset Management tasks

- Visitor mode avoiding interference with network behavior
- Enabling asset management systems (e.g. Emerson's AMS) and Field Device Tool (FDT) frame applications (e.g. SMART VISION, FieldMate, Field Device Manager, FieldCare, or PACTware)

### All Necessary Tools Included

- FF Configuration Tool for configuration of devices and cyclic communication
- PACTware for device configuration and basic asset management tasks

# FG-200

## Technical Data

<b>Hardware</b>	Processor	Altera Cyclone V SoC with dual-core ARM Cortex-A9
	Status LEDs (Gateway) Status LEDs (Fieldbus)	PWR (power supply), RUN (operation), ERR (error), RDL (redundancy link) FF H1 activity per link
<b>Interfaces and Connectors</b>	Ethernet	2 * IEEE 802.3 100BASE-TX / 10BASE-T (only ETH1 supported) Connectors: RJ45
	FOUNDATION Fieldbus H1	4 FF H1 links, compliant to type 114 of FF physical layer profile (each link capable to operate independently as Link Master and/or Time Master) Transfer rate: 31.25 Kbit/s Fieldbus voltage range: 9 VDC ... 32 VDC, preferred voltage: 24 VDC Current consumption: 10 mA / link Connectors: 3-position screw connection, galvanically isolated
<b>Physical Properties</b>	Dimensions (H x W x D)	100 mm x 35 mm x 105 mm
	Weight	Approx. 0.25 kg
	Power Supply	18 VDC ... 32 VDC; SELV/PELV power supply mandatory; Typical input current: 200 mA, maximum input current: 1 A (allowing for in-rush current at switch-on) No power supply to FF H1 links through FG-200 HSE/FF Modbus
	Operating / Storage Temperature	-40 °C .. +70 °C / -40 °C .. +85 °C (see detailed mounting description in user manual)
	Relative Humidity	10 % ... 95 %, non-condensing
	Cooling	Convection, no fan
	Coating	Conformal coating based on ANSI / ISA-S71.04 G3
	Mounting Protection Class	DIN rail 35 mm IP20
<b>Software</b>	Protocols Redundancy	FOUNDATION Fieldbus H1, FOUNDATION Fieldbus HSE, Modbus TCP Device redundancy compliant to type D-3 according to specification FF-593
	<b>Conformity / Certifications</b>	CE
Electromagnetic Compatibility (EMC)		FCC CFR45, Part 15 Section 15.107 and 15.109 (Class A), VCCI Class A Information Technology Equipment 2002
Vibration / Shock		DIN EN 60068-2-6 Vibration / DIN EN 60068-2-27 Shock
Hazardous Location Certifications		cULus: Class 1, Division 2, Groups A, B, C, D (in preparation) IECEX: Ex nA [ic] IIC T4 Gc ATEX: II 3G nA [ic] IIC T4 Gc

## Scope of Delivery

Hardware	FG-200
Software	FF Configuration Tool, FDT CommDTM, PACTware on CD-ROM
Documentation	Quick Startup Guide, User Manual on CD-ROM

## Order Numbers

GLA-EK-024102	FG-200
GLA-EK-024103	FG-200 HSE/FF Modbus, functionally identical design variant for use with R. STAHL bus-Carrier Series 9419 and Fieldbus Power Supply 9412 products

Your local Softing contact:



**TM Solutions inc.**

[www.tmsolutions.co.kr](http://www.tmsolutions.co.kr)

e-mail : [sales@tmsolutions.co.kr](mailto:sales@tmsolutions.co.kr)

TEL : +82-2-784-2526

<http://industrial.softing.com>

optimize!  
**softing**